

INTERACTIVE DISPLAY

The ActivTable is an interactive table with a 46-inch HD LCD touch-sensitive display that supports up to six students at one time. Includes extensive educational activities, an image bank and reporting tools. ActivTable offers integrated speakers and wheels as standard.

GENERAL SPECIFICATIONS

User Input	Touch
Number of Touches	12 perfect simultaneous touches
Touch Technology	Infra-red based detection system
Display Technology	Horizontal HD LCD Panel
Power Requirement	Mains Powered; Dual Voltage 100 - 240v AC
Power Consumption	Standby 0.15A (36W), In Use 1.2A (288W) (Based on 240v mains)
Connectivity	4 x USB-A ports, 3.5mm mic in socket, 4 x 3.5 mm stereo headphone sockets, DVI, Ethernet port, WiFi
Screen Surface	Toughened Safety Glass
Certifications	UL, CE, FCC
Integrated Sound	Two integrated 10W speakers and integrated class-D amplifier (volume controlled via the ActivTable software)
Packed Contents List	ActivTable including ActivTable software, educational activities, tools and resources, embedded training resources and Quick Start Guide, Installation Guide, Health and Safety Guide, Power Cords x4 (AU, EU, UK, US), Allen key, fixings and Cover.



SPECIFICATIONS

Active Area Diagonal	1170mm (46")
Resolution	1920x1080
Screen Formats	16:9
Overall Dimensions	1200mm x 752mm x 725mm (47.2in x 29.6in x 28.5in)
Active Area Dimensions	1020mm x 572mm (40.2in x 22.5in)
Mobility	4 free-wheeling castors, plus locking feet to secure ActivTable in position
Operating Temperature	5°C to 30°C (41°F to 86°F)
Storage Temperature	-20°C to 60°C (-4°F to 140 °F)
Table Weight	69.5kg (153lbs)
Packed Weight & Dimensions	<p>Box 1 of 3: 64.7kg (142.3lbs) Dimensions: 1280mm x 840mm x 215mm (50.4in x 33.1in x 8.5in) T-SURFACE Contents: Table surface, Installation Guide, Health and Safety Guide.</p> <p>Box 2 of 3 23.3kg (51.3lbs) Dimensions: 755mm x 390mm x 377mm (29.7in x 15.4in x 14.8in) T-LEGS-M Contents: Table legs, power cords x4 (AU, EU, UK, US), Allen Key and fixings</p> <p>Box 3 of 3 2kg (4.5lbs) Dimensions: 780mm x 430mm x 50mm (31in x 17in x 2in) T-COVER Contents: ActivTable Cover</p>

MINIMUM COMPUTER REQUIREMENTS

Operating Systems	Microsoft Windows Embedded Standard 7
Internet	Internet access required – wireless or wired

INSTALLATION

ActivTable

It is recommended that the ActivTable is installed by a Certified Promethean Installer. Two people will be required to install the ActivTable. A keyboard and mouse will be required for set up (not supplied). For optimum performance, Promethean recommends the ActivTable is installed away from direct lighting or sunlight.

Components supplied and minimum specifications stated have been tested and are required for optimal performance. Use of components not supplied by Promethean or not meeting minimum specifications may impact performance and affect warranty. Contact your Promethean partner or visit www.PrometheanKB.com for more information.

UPGRADE AND ACCESSORY OPTIONS

Headphone Accessory Kit

Allows up to 6 users to use headphones, users will hear the same audio. Accessory kit will include 6 wired headphones and 2 x headphone socket splitters.

WARRANTY AND SUPPORT[†]

ActivTable

For Promethean Warranty Information please visit: www.PrometheanWorld.com/ActivCare
Online support for all Promethean Products available at: www.PrometheanKB.com

TECHNICAL DRAWING

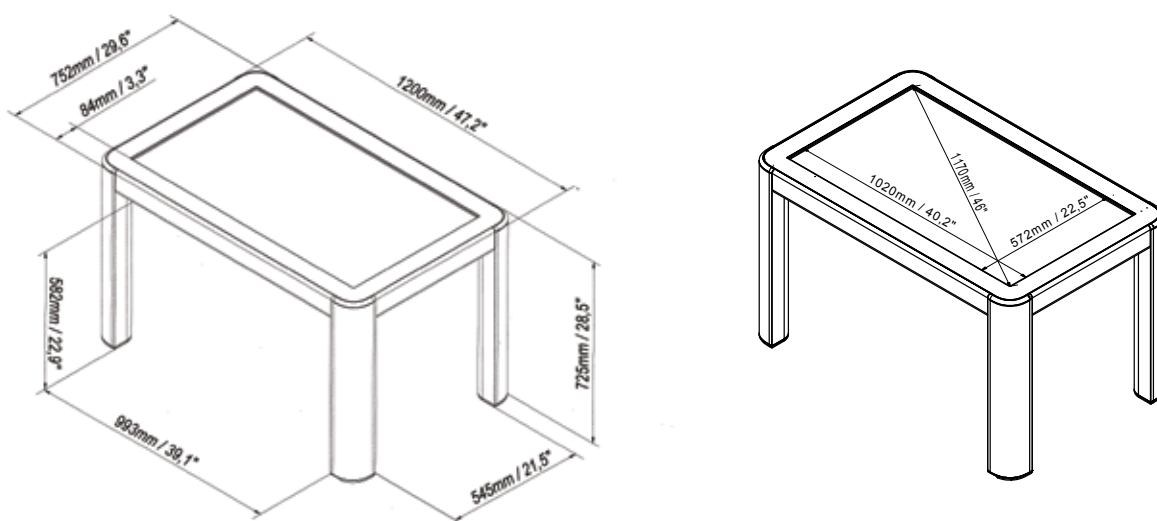

Contact GT Innovations - Promethean Premium Partner for Victoria.

Ph: 9560 9022 Email: info@gtinnovations.com.au Web: www.gtinnovations.com.au

ActivTable S5 10/12 V1.4 UK

Page 2